

Technical Information for Methane Gas Sensors

The Figaro 2600 series is a thick film metal oxide semiconductor, screen printed gas sensor which offers miniaturization and lower power consumption. The TGS2611 displays high selectivity and sensitivity to methane.



| | <u>Page</u> |
|--|-------------|
| Basic Information and Specifications | |
| <i>Features</i> | 2 |
| <i>Applications</i> | 2 |
| <i>Structure</i> | 2 |
| <i>Basic Measuring Circuit</i> | 2 |
| <i>Circuit & Operating Conditions</i> | 3 |
| <i>Specifications</i> | 3 |
| <i>Dimensions</i> | 3 |
| Typical Sensitivity Characteristics | |
| <i>Sensitivity to Various Gases</i> | 4 |
| <i>Temperature and Humidity Dependency</i> | 5 |
| <i>Heater Voltage Dependency</i> | 6 |
| <i>Gas Response</i> | 6 |
| <i>Initial Action</i> | 7 |
| <i>Long Term Characteristics</i> | 7 |
| Reliability | |
| <i>Ignition Test</i> | 8 |
| <i>HMDS Test</i> | 8 |
| Cautions | 9 |

See also Technical Brochure ‘Technical Information on Usage of TGS Sensors for Toxic and Explosive Gas Leak Detectors’.

IMPORTANT NOTE: OPERATING CONDITIONS IN WHICH FIGARO SENSORS ARE USED WILL VARY WITH EACH CUSTOMER’S SPECIFIC APPLICATIONS. FIGARO STRONGLY RECOMMENDS CONSULTING OUR TECHNICAL STAFF BEFORE DEPLOYING FIGARO SENSORS IN YOUR APPLICATION AND, IN PARTICULAR, WHEN CUSTOMER’S TARGET GASES ARE NOT LISTED HEREIN. FIGARO CANNOT ASSUME ANY RESPONSIBILITY FOR ANY USE OF ITS SENSORS IN A PRODUCT OR APPLICATION FOR WHICH A SENSOR HAS NOT BEEN SPECIFICALLY TESTED BY FIGARO.



TGS2611-E is a UL recognized component in accordance with the requirements of UL2075. Please note that component recognition testing has confirmed long term stability in 60ppm of methane; other characteristics shown in this brochure have not been confirmed by UL as part of component recognition.

1. Basic Information and Specifications

1-1 Features

- * High selectivity to methane
- * Low power consumption
- * Small size
- * Long life and low cost
- * Uses simple electrical circuit

1-2 Applications

- * Residential gas alarms
- * Portable gas detectors
- * Gas leak detectors for gas appliances

1-3 Structure

Figure 1 shows the structure of TGS2611. Using thick film techniques, the sensing material (SnO₂) is printed on electrodes (noble metal) which have been printed onto an alumina substrate. One electrode is connected to pin No.2 and the other is connected to pin No.3. The sensor element is heated by RuO₂ material printed onto the reverse side of the substrate and connected to pins No.1 and No.4.

Lead wires are Pt-W alloy and are connected to sensor pins which are made of Ni-plated Ni-Fe 50%.

The sensor base is made of Ni-plated steel. The cap is stainless steel. The upper opening in the cap is covered with a double layer of 100 mesh stainless steel gauze (SUS316). The TGS2611-E utilizes a proprietary filter material inside the cap for reducing the influence of interference gases.

1-4 Basic measuring circuit

Figure 2 shows the basic measuring circuit. Circuit voltage (V_c) is applied across the sensor element which has a resistance (R_s) between the sensor's two electrodes and the load resistor (R_L) connected in series. When DC is used for V_c, the polarity shown in Figure 2 **must** be maintained. The V_c may be applied intermittently. The sensor signal V_{OUT} (V_{RL}) is measured indirectly as a change in voltage across the R_L. The R_s is obtained from the formula shown at the right.

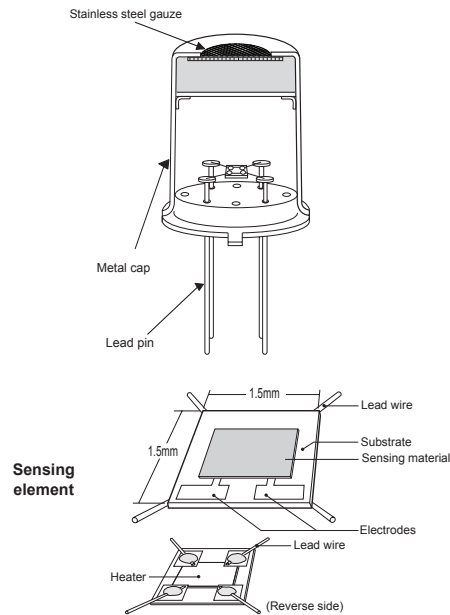

Fig. 1 - Sensor structure

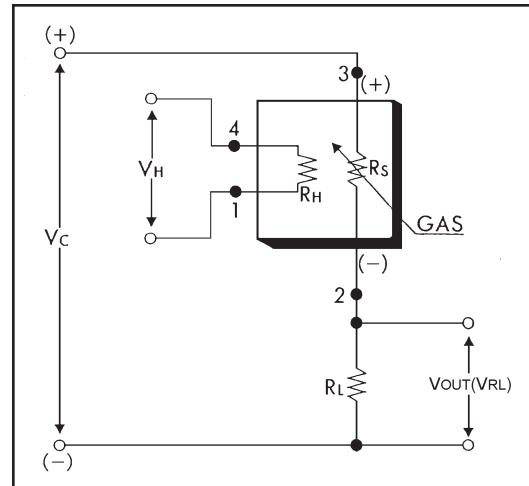

Fig. 2 - Basic measuring circuit

NOTE: In the case of V_H, there is no polarity, so pins 1 and 4 can be considered interchangeable. However, in the case of V_C, when used with DC power, pins 2 and 3 must be used as shown in the Figure above.

$$R_s = \left(\frac{V_c}{V_{RL}} - 1 \right) \times R_L$$

Formula to determine R_s

1-5 Circuit & operating conditions

The ratings shown below should be maintained at all times to insure stable sensor performance:

| Item | Specification |
|--|------------------------|
| Circuit voltage (V _C) | 5.0V ± 0.2V DC |
| Heater voltage (V _H) | 5.0V ± 0.2V DC |
| Inrush heater current (V _H =5.0V) | 100mA max. |
| Heater resistance (room temp) | approx 59Ω |
| Load resistance (R _L) | variable (0.45kΩ min.) |
| Sensor power dissipation (P _s) | ≤15mW |
| Operating & storage temperature | -40°C ~ +70°C |
| Typical detection range | 1~25% LEL |

1-6 Specifications NOTE 1

| Item | Specification |
|---|----------------|
| Sensor resistance (5000ppm methane) | 0.83kΩ ~ 8.3kΩ |
| Sensor resistance ratio (β) | 0.52 ~ 0.65 |
| $\beta = R_s(9000\text{ppm methane})/R_s(3000\text{ppm methane})$ | |
| Heater current (R _H) | 56 ± 5mA |
| Heater power consumption (P _H) | 280m±25W |

NOTE 1: Sensitivity characteristics are obtained under the following standard test conditions:

(Standard test conditions)

Temperature and humidity: 20 ± 2°C, 65 ± 5% RH

Circuit conditions: V_C = 5.0±0.01V DC

V_H = 5.0±0.05V DC

R_L = 10.0kΩ ± 1%

Preheating period: 4 days or more under standard circuit conditions.

All sensor characteristics shown in this brochure represent typical characteristics. Actual characteristics vary from sensor to sensor and from production lot to production lot. The only characteristics warranted are those shown in the Specification table above.

1-7 Dimensions

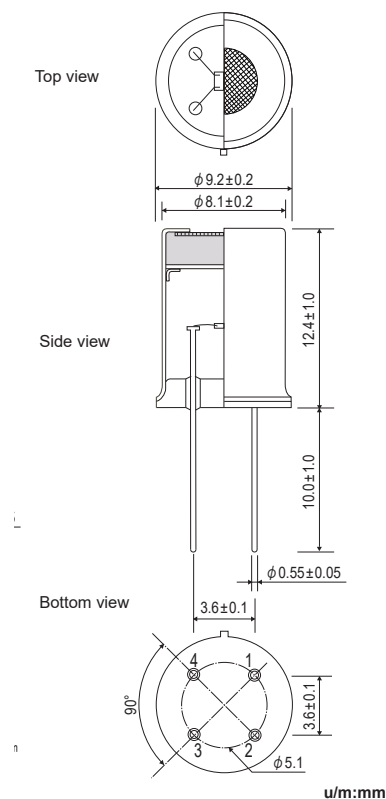

Pin connection:

- 1: Heater
- 2: Sensor electrode (-)
- 3: Sensor electrode (+)
- 4: Heater

Fig. 3 - Sensor dimensions

Mechanical Strength:

The sensor shall have no abnormal findings in its structure and shall satisfy the above electrical specifications after the following performance tests:

Withdrawal Force - withstand force of 5kg in each direction
(pin from base)

Vibration - frequency-1000cycles/min., total amplitude-4mm, duration-one hour, direction-vertical

Shock - acceleration-100G, repeated 5 times

2. Typical Sensitivity Characteristics

2-1 Sensitivity to various gases

Figure 4 shows the relative sensitivity of TGS2611 to various gases. The Y-axis shows the ratio of the sensor resistance in various gases (R_s) to the sensor resistance in 5000ppm of methane (R_o).

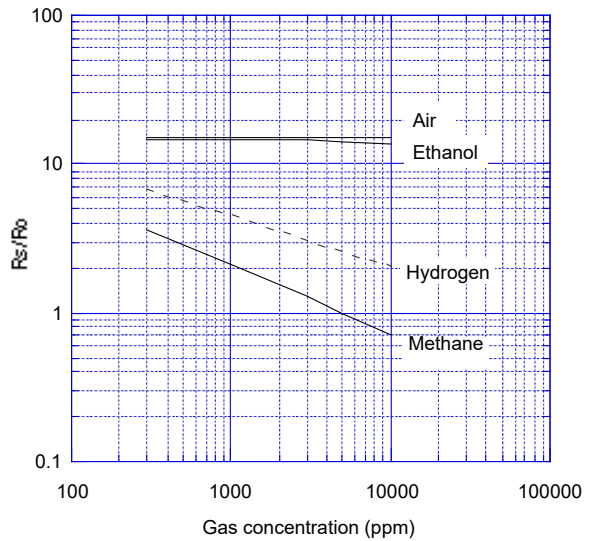

Fig. 4 - Sensitivity to various gases (R_s/R_o)

Using the basic measuring circuit illustrated in Figure 2, and with a matched RL value equivalent to the R_s value in 5000ppm of methane will provide sensor output voltage (VRL) change as shown in Figure 5.

NOTE:

All sensor characteristics in this technical brochure represent typical sensor characteristics. Since the R_s or output voltage curve varies from sensor to sensor, calibration is required for each sensor (*for additional information on calibration, please refer to the Technical Advisory 'Technical Information on Usage of TGS Sensors for Toxic and Explosive Gas Leak Detectors'*).

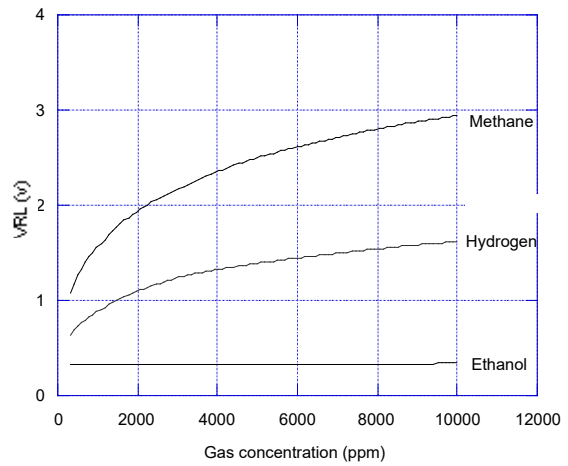

Fig. 5 - Sensitivity to various gases (VRL)

2-2 Temperature and humidity dependency

Figure 6 shows the temperature and humidity dependency of TGS2611. The Y-axis shows the ratio of sensor resistance in 5000ppm of methane under various atmospheric conditions (R_s) to the sensor resistance in 5000ppm of methane at 20°C/65%RH (R_o).

| RH (°C) | RH | | | | |
|------------|-------|-------|-------|-------|-------|
| | 35%RH | 50%RH | 65%RH | 80%RH | 95%RH |
| -10 | | | 1.40 | | |
| 5 | | | 1.24 | 1.20 | 1.27 |
| 20 | 1.13 | 1.09 | 1.00 | 1.05 | 1.06 |
| 35 | 0.96 | 0.90 | 0.87 | 0.90 | 0.88 |
| 50 | 0.84 | 0.80 | 0.74 | 0.76 | 0.74 |

Table 1 - Temperature and humidity dependency (typical values of R_s/R_o for Fig. 6)

Table 1 shows a table of values of the sensor's resistance ratio (R_s/R_o) under the same conditions as those used to generate Figure 6.

Figure 7 shows the sensitivity curve for TGS2611 to methane under several ambient conditions. While temperature may have a large influence on absolute R_s values, this chart illustrates the fact that effect on the slope of sensor resistance ratio (R_s/R_o) is not significant. As a result, the effects of temperature on the sensor can easily be compensated.

For economical circuit design, a thermistor can be incorporated to compensate for temperature (for additional information on temperature compensation in circuit designs, please refer to the Technical Advisory 'Technical Information on Usage of TGS Sensors for Toxic and Explosive Gas Leak Detectors').

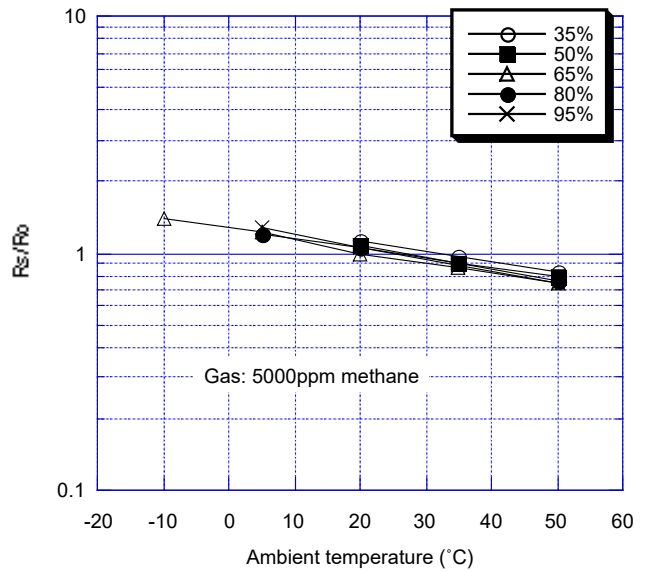

Fig. 6 - Temperature and humidity dependency (R_s/R_o)

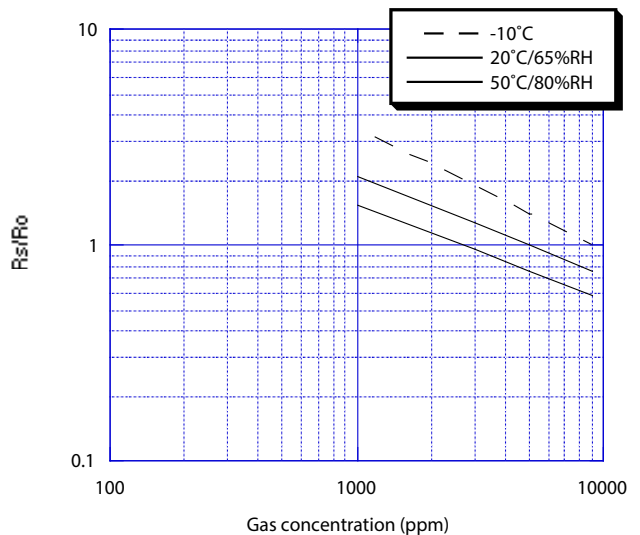

Fig. 7 - Resistance change ratio under various ambient conditions

2-3 Heater voltage dependency

Figure 8 shows the change in the sensor resistance ratio according to variations in heater voltage (VH).

Note that 5.0V as a heater voltage must be maintained because variance in applied heater voltage will cause the sensor's characteristics to be changed from the typical characteristics shown in this brochure.

2-4 Gas response

Figure 9 shows the change pattern of sensor resistance (Rs) for TGS2611 when the sensor is inserted into and later removed from 5000ppm of methane.

As these charts display, the sensor's response speed to the presence of gas is extremely quick, and when removed from gas, the sensor will recover back to its original value in a short period of time.

Figure 10 demonstrates the sensor's repeatability by showing multiple exposures to a 5000ppm concentration of methane. Unlike the test done for Figure 9, here the sensor is located in a single environment which is exchanged periodically. As a result, though the process of gas diffusion reduces sensor response speed, good repeatability can be seen.

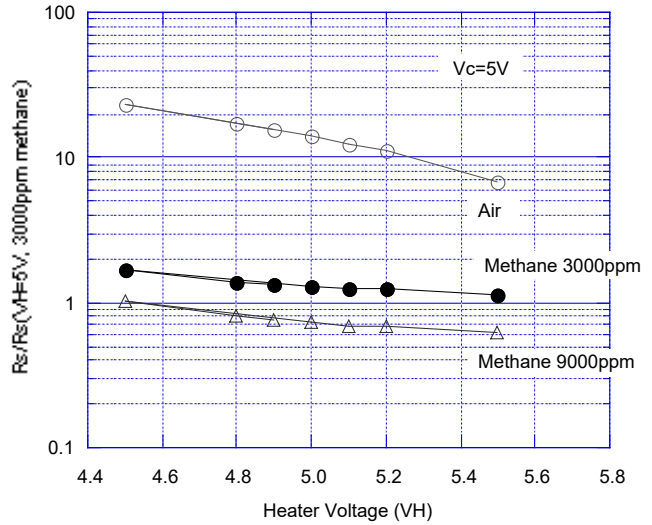

Fig. 8 - Heater voltage dependency (Vc=5.0)

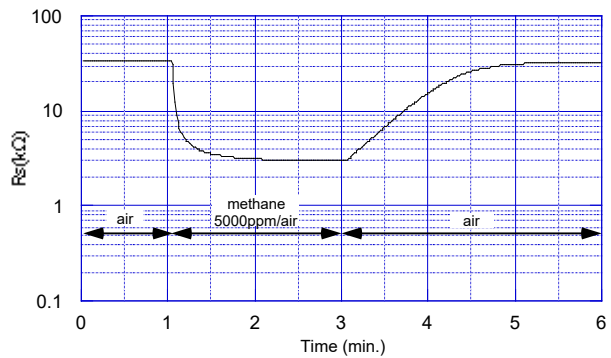

Fig. 9 - Gas response to methane

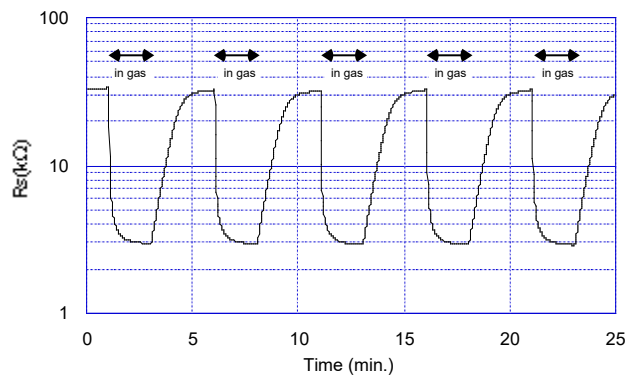

Fig. 10 - Repeatability

2-5 Initial action

Figure 11 shows the initial action of the sensor resistance (Rs) for a sensor which is stored unenergized in normal air for 90 days and later energized in clean air.

The Rs drops sharply for the first seconds after energizing, regardless of the presence of gases, and then reaches a stable level according to the ambient atmosphere. Such behavior during the warm-up process is called “Initial Action”.

Since this ‘initial action’ may cause a detector to alarm unnecessarily during the initial moments after powering on, it is recommended that an initial delay circuit be incorporated into the detector’s design (refer to *Technical Advisory ‘Technical Information on Usage of TGS Sensors for Toxic and Explosive Gas Leak Detectors’*). This is especially recommended for intermittent-operating devices such as portable gas detectors.

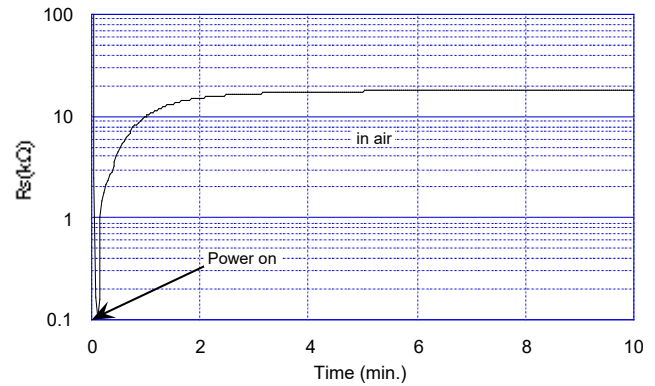

Fig. 11 - Initial action

2-6 Long-term characteristics

Figure 12 shows long-term stability of TGS2611 as measured for more than 1900 days. The sensor is usually energized in normal air. Measurement for confirming sensor characteristics is conducted under standard test conditions. The initial value of Rs was measured after preheating for at least three days in normal air at the rated voltage. The Y-axis represents the sensor resistance in air, 5000ppm of methane, 3000ppm of hydrogen, and 3000ppm of ethanol.

The Rs in methane is very stable over the test period.

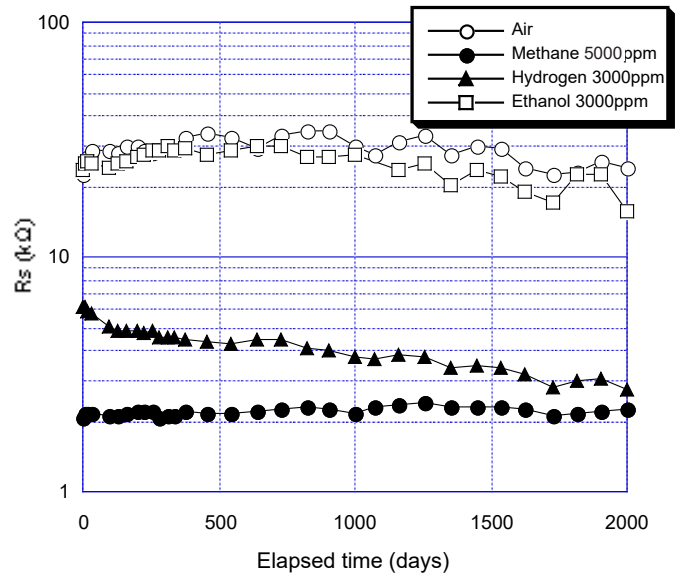

Fig. 12 - Long-term stability (continuous energizing)

3. Reliability

3-1 Ignition test (*)

TGS2611 has been successfully tested against the ignition test requirements of the UL1484 standard. The sensor did not initiate ignition of a propane concentration of 5.25% by volume.

3-2 HMDS test

Figure 13 shows the effect on TGS2611 of silicone vapor. Sensor resistance prior to HMDS (Hexamethyl disiloxane) gas exposure was measured (R_0). Energized sensors were placed into an environment of 20°C/50%RH. In this environment, the sensors were exposed to HMDS at 10 ppm for 40 minutes, 30 ppm for 40 minutes and 100 ppm for 40 minutes (test conditions specified in Item 5.3.13 of the ES (European standard) EN50194: 10ppm for 40 min.). After exposure, the sensor was returned to normal air. Sensor resistance (R_s) in both air and 5000ppm of methane were measured at 1 hour, 1 day, and 1 week after being removed from HMDS.

As this data would suggest, sensor characteristics remain largely unaffected by exposure to HMDS gas concentrations.

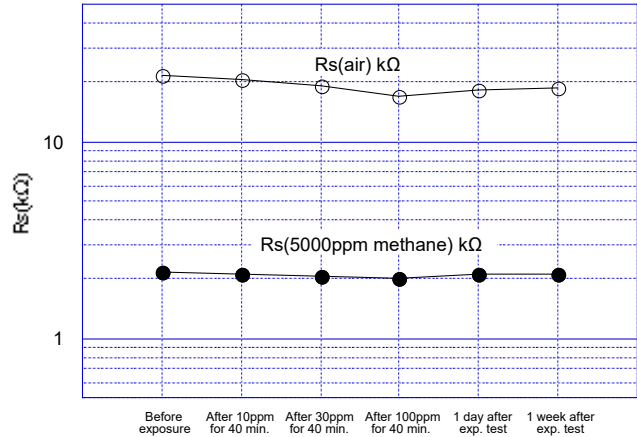

Fig. 13 - Durability to HMDS exposure

(*) The UL 1484 referenced tests have not been reviewed or accepted by Underwriters Laboratory as part of the component recognition.

4 Cautions

4-1 Situations which must be avoided

1) Exposure to silicone vapors

If silicone vapors adsorb onto the sensor's surface, the sensing material will be coated, irreversibly inhibiting sensitivity. Avoid exposure where silicone adhesives, hair grooming materials, or silicone rubber/putty may be present.

2) Highly corrosive environment

High density exposure to corrosive materials such as H₂S, SO_x, Cl₂, HCl, etc. for extended periods may cause corrosion or breakage of the lead wires or heater material.

3) Contamination by alkaline metals

Sensor drift may occur when the sensor is contaminated by alkaline metals, especially salt water spray.

4) Contact with water

Sensor drift may occur due to soaking or splashing the sensor with water.

5) Freezing

If water freezes on the sensing surface, the sensing material would crack, altering characteristics.

6) Application of excessive voltage

If higher than specified voltage is applied to the sensor or the heater, lead wires and/or the heater may be damaged or sensor characteristics may drift, even if no physical damage or breakage occurs.

7) Operation in zero/low oxygen environment

TGS sensors require the presence of around 21% (ambient) oxygen in their operating environment in order to function properly and to exhibit characteristics described in Figaro's product literature. TGS sensors cannot properly operate in a zero or low oxygen content atmosphere.

8) Excessive exposure to alcohol

IF TGS2611-E00 is exposed to high concentrations of alcohol (such as 10,000ppm or more) for a long period of time, the filter may become saturated. In this case, the sensor would show a lower resistance in alcohol than that indicated in Figure 4.

9) Polarization

These sensors have polarity. Incorrect V_c connection may cause significant deterioration of long term stability. Please connect V_c according to specifications.

10) Lighter gas exposure test

Consumers often check if detectors are actually sensing gas by exposing them to lighter gas (main component is iso-butane). Because the filter will block iso-butane from reaching the sensing element, this test **cannot** be used with TGS2611-E00.

11) Pin handling

Do not bend or twist the pins or twist the sensor cap when mounting the sensor on a circuit board or removing the sensor from a circuit board after soldering. If excessive stress is applied to the glass seal at the pin exit on the sensor base due to improper handling, the glass seal may be broken or damaged, which may result in deterioration of the sensor performance because poisonous gases or interference gases may enter the sensor housing through the broken glass seal.

4-2 Situations to be avoided whenever possible

1) Water condensation

Light condensation under conditions of indoor usage should not pose a problem for sensor performance. However, if water condenses on the sensor's surface and remains for an extended period, sensor characteristics may drift.

2) Usage in high density of gas

Sensor performance may be affected if exposed to a high density of gas for a long period of time, regardless of the powering condition.

3) Storage for extended periods

When stored without powering for a long period, the sensor may show a reversible drift in resistance according to the environment in which it was stored. The sensor should be stored in a sealed bag containing clean air; do not use silica gel. *Note that as unpowered storage becomes longer, a longer preheating period is required to stabilize the sensor before usage.*

4) Long term exposure in adverse environment

Regardless of powering condition, if the sensor is exposed in extreme conditions such as very high humidity, extreme temperatures, or high contamination levels for a long period of time, sensor performance will be adversely affected.

5) Vibration

Excessive vibration may cause the sensor or lead wires to resonate and break. Usage of compressed air drivers/ ultrasonic welders on assembly lines may generate such vibration, so please check this matter.

6) Shock

Breakage of lead wires may occur if the sensor is subjected to a strong shock.

4-3 Sensor mounting

1) Soldering

Ideally, sensors should be soldered manually. However, wave soldering can be done under the following conditions:

- a) Suggested flux: rosin flux with minimal chlorine
- b) Speed: 1-2 meters/min.
- c) Preheating temperature: $100 \pm 20^\circ\text{C}$
- d) Solder temperature: $250 \pm 10^\circ\text{C}$
- e) Up to two passes through wave soldering machine allowed

Results of wave soldering cannot be guaranteed if conducted outside the above guidelines since some flux vapors may cause drift in sensor performance similar to the effects of silicone vapors.

2) Printed wiring board design

The recommended land pattern of PWB for mounting a gas sensor is shown in Figure 14.

- a) The insertion hole ($\phi 0.8$) for sensor lead pins should be a non-plated and non-through hole.
- b) There should be no wiring pattern on the PWB surface on which the sensor will be mounted. Wiring patterns should only be designed on the opposite side of the PWB.
- c) It is best to design a land pattern so that a sensor can easily be mounted on. The land pattern shown in Figure 16 is a recommended example only.

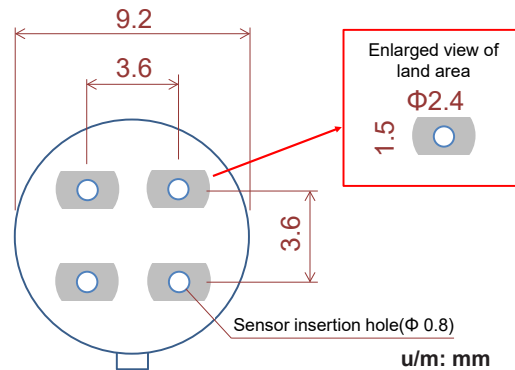

Fig. 14 - Recommended land pattern

NOTE: To achieve the optimal level of accuracy in gas detectors, each TGS2611 sensor should be individually calibrated by matching it with a load resistor (RL) in an environment containing the target gas concentration for alarming (refer to Figure 2).

For the convenience of users, TGS2611 is classified into 24 groups according to the each sensor's Rs in methane. ID numbers marked on the sensor's body indicate the sensor's grouping. Individual sensor calibration can be eliminated by matching the sensor with the recommended RL for each sensor ID. However, because group calibration is used instead of individual calibration, an average of 10% less accuracy would result for detectors using group calibration. Please refer to "Application Notes for TGS2611-E00" for more information.

Figaro USA Inc. and the manufacturer, Figaro Engineering Inc. (together referred to as Figaro) reserve the right to make changes without notice to any products herein to improve reliability, functioning or design. Information contained in this document is believed to be reliable. However, Figaro does not assume any liability arising out of the application or use of any product or circuit described herein; neither does it convey any license under its patent rights, nor the rights of others.

Figaro's products are not authorized for use as critical components in life support applications wherein a failure or malfunction of the products may result in injury or threat to life.

